

vertical single-stage deep well jet pumps



The SSJ Series Vertical Jet Pumps are the industry standard deep well jet pumps for over-the-well "bolt-on" installations.

The SSJ Series Jet Pumps include the pre-plumbed STA-RITE external automatic regulator, pressure gauge, pressure switch, and a complete line of casing adapters to drive the 4" double pipe or 2" and 3" single pipe jet packages.

APPLICATIONS

- **Water systems and sprinkling...** for homes, farms and cottages.

SPECIFICATIONS

- Body** – Rugged cast iron
- Pump and Motor Shaft** – Stainless steel
- Impellers** – Noryl®
- Diffuser** – Heavy-duty cast iron

SSJ SERIES

FEATURES

Automatic Pressure Regulator – Faster-acting, quieter design eliminates "hunting" for correct drive pressure. New improved stem and guide are precisely molded to assure efficient, trouble-free performance on all deep wells.

Quality Construction – Precision-machined, close-grained cast iron pump body and base are specially treated to resist corrosion.

Noryl® Impellers – Precision molded for perfect balance, and ultra-smooth for highest performance and efficiency.

Pressure Switch – High quality. Differential and cut-in/cut-out pressure settings are adjustable.

Dustproof Cover – All electrical components are protected from dirt, dust and insects by a dustproof canopy. Ventilating air cannot contaminate vital switching components. This eliminates the most common cause of motor failure.

Motor Windings – Superior insulation materials protect against excessive moisture and contaminants to ensure prolonged motor life.

Balanced Rotor – Rotor is die cast under high pressures for uniform performance and greater efficiency; dynamically balanced.

Heavy-duty Ball Bearings – Shielded, permanently lubricated bearings are extensively tested to ensure extended life and smooth, quiet operation.

Pump and Motor Shaft – One piece threaded shaft for positive impeller drive and alignment. Shaft is stainless steel for maximum corrosion resistance.

ORDERING INFORMATION

Catalog Number	HP	Description	Pipe Tapping Sizes			Motor Voltage	Approx. Wt. Lbs.
			Suct.	Drive	Disch.		
SSJC	1/2	Base Mounted Pump	1-1/4"	1"	1"	115/230	53
SSJD	3/4	Base Mounted Pump	1-1/4"	1"	1"	115/230	63
SSJE	1	Base Mounted Pump	1-1/4"	1"	1"	115/230	65

ADAPTER FLANGE*

Catalog Number	Description	Used With
J216-26	1-1/4" x 1"	Offset single pipe and 4" double pipe

*Required for all 4" double pipe or offset installations.

NOTE: Order pump from ordering information table above. A Jet Package should be ordered with every SSJ Series Pump. All installations require an appropriate size adapter flange or casing adapter.

Noryl® is registered trademark of General Electric Co. PRO-Source™ is a trademark of WICOR Industries.

In order to provide the best products possible, specifications are subject to change.

vertical single-stage deep well jet pumps

OUTLINE DIMENSIONS

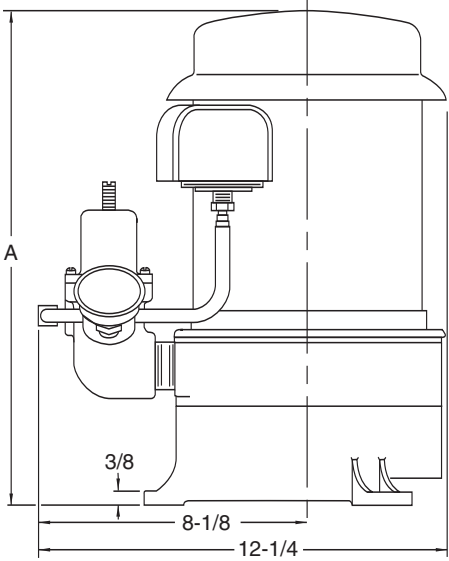

Cat. No.	A
SSJC	14-1/2
SSJD	15-1/8
SSJE	16-3/16

Dimensions (in inches) are for estimating purposes only.

PUMP PERFORMANCE <i>(Capacity in Gallons Per Minute)</i>																			
DEEP WELL (40 PSI) 4" DOUBLE PIPE																			
Cat. No.	HP	Jet No.	Use Venturi	Use Nozzle	Pumping Depth in Feet													Max. Pump Shut Off Pressure (PSI)	
					20'	30'	40'	50'	60'	70'	80'	90'	100'	110'	120'	130'	Jet at Min. Depth	Jet at Max. Depth	
SSJC	1/2	1SSD	J32P-18	J34P-42		4.8	4.3	3.7	3.0	2.4	1.8	1.5	1.0	0.5			91	50	
		CK4	J32P-32	J34P-35	9.5	7.0	4.5	2.0									62	44	
		4SD	J32P-24	J34P-41		6.5	5.1	4.0	3.0	1.8	0.8							75	45
SSJD	3/4	CK1	J32P-22	J34P-43		8.3	7.4	6.3	5.3	3.8	3.5	2.6	1.8	1.0			88	46	
		CK3	J32P-32	J34P-41		10.0	6.4	3.0									57	46	
		4SD	J32P-24	J34P-41		8.6	7.5	6.5	5.2	4.0	2.9	1.8	0.8				93	51	
SSJE	1	CK1	J32P-22	J34P-43		8.6	7.8	6.6	5.6	4.5	3.6	2.8	2.3	1.7	1.1	0.6	98	47	
		CK4	J32P-28	J34P-45		11.4	10.7	9.6	8.3	7.0	5.0	3.3	1.6				102	48	
		CK4	J32P-38	J34P-45	17.0	13.2	9.5	5.8	2.2								66	44	

Tested and rated in accordance with Water Systems Council Standards.

NOTE: Pumps installed with a PRO-Source™ tank require a 100 PSI relief valve. Pumps installed with a conventional tank require a 75 PSI relief valve. Relief valve must be capable of relieving entire flow of pump at relief pressure.



vertical single-stage deep well jet pumps

PUMP PERFORMANCE (Capacity in Gallons Per Minute)																		
DEEP WELL (40 PSI) 2" SINGLE PIPE																		
Cat. No.	HP	Jet No.	Use Venturi	Use Nozzle	Pumping Depth in Feet												Max. Pump Shut Off Pressure (PSI)	
					20'	30'	40'	50'	60'	70'	80'	90'	100'	110'	120'	130'	Jet at Min. Depth	Jet at Max. Depth
SSJC	1/2	14AP	J32P-32	J34P-45	9.2	6.7	4.3										61	49
		10AP	J32P-24	J34P-44		6.2	4.8	3.7	2.3	1.2							71	47
		8AP	J32P-18	J34P-42		4.1	3.7	3.1	2.6	2.1	1.6	1.2	0.8				94	53
SSJD	3/4	15AP	J32P-33	J34P-41	12.3	9.2	5.7										57	48
		9AP	J32P-29	J34P-44		10.6	7.4	4.7	2.3								64	47
		8AP	J32P-18	J34P-42		5.0	4.7	4.2	3.8	3.3	3.3	2.3	1.8	1.3			109	62
SSJE	1	16AP	J32P-38	J34P-45	15.3	11.8	8.5	5.2									65	48
		9AP	J32P-29	J34P-44		12.3	9.3	6.4	4.0								72	53
		8AP	J32P-18	J34P-42		5.7	5.0	4.6	4.2	3.7	3.3	2.8	2.4	1.8	1.3		124	66
DEEP WELL (40 PSI) 3" SINGLE PIPE																		
SSJC	1/2	19CP	J32P-24	J34P-41		6.5	5.1	4.0	3.0	1.8	0.8						75	45
		16CP	J32P-18	J34P-42		4.8	4.3	3.7	3.0	2.4	1.8	1.5	1.0	0.5			91	50
		11CP	J32P-32	J34P-45	9.5	7.0	4.5	2.0									62	44
SSJD	3/4	26CP	J32P-33	J34P-41	13.0	9.8	6.0										58	49
		19CP	J32P-24	J34P-41		8.6	7.5	6.5	5.2	4.0	2.9	1.8	0.8				93	51
		17CP	J32P-29	J34P-44		11.5	8.0	5.2	2.6								66	48
		15CP	J32P-22	J34P-43		8.3	7.4	6.3	5.3	3.8	3.5	2.6	1.8	0.1			88	46
SSJE	1	19CP	J32P-24	J34P-41		7.9	7.5	7.2	6.5	5.6	4.4	2.8					105	69
		15CP	J32P-22	J34P-43		8.6	7.8	6.6	5.6	4.5	3.6	2.8	2.3	1.7	1.1	0.6	98	47
		10CP	J32P-38	J34P-45	17.0	13.2	9.5	5.8	2.2							66	44	

Tested and rated in accordance with Water Systems Council Standards.

NOTE: Pumps installed with a PRO-Source™ tank require a 100 PSI relief valve. Pumps installed with a conventional tank require a 75 PSI relief valve. Relief valve must be capable of relieving entire flow of pump at relief pressure.

vertical single-stage deep well jet pumps

OUTLINE DIMENSIONS

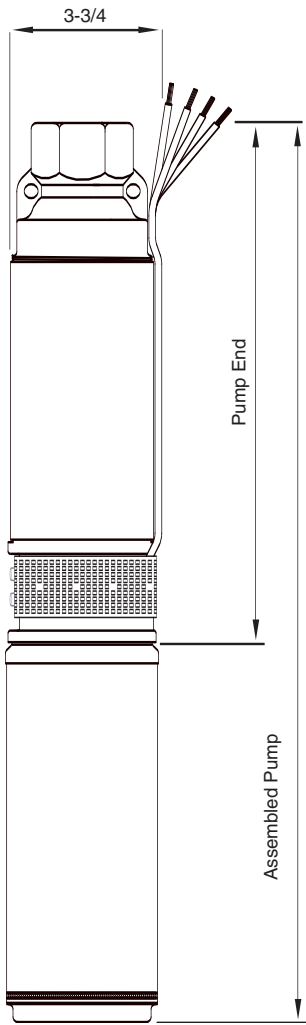

3-3/4

Pump End

Assembled Pump

Discharge	
5 GPM	1-1/4" NPT
7 GPM	1-1/4" NPT

For dimensions, refer to Ordering Information table.

Dimensions (in inches) are for estimating purposes only.

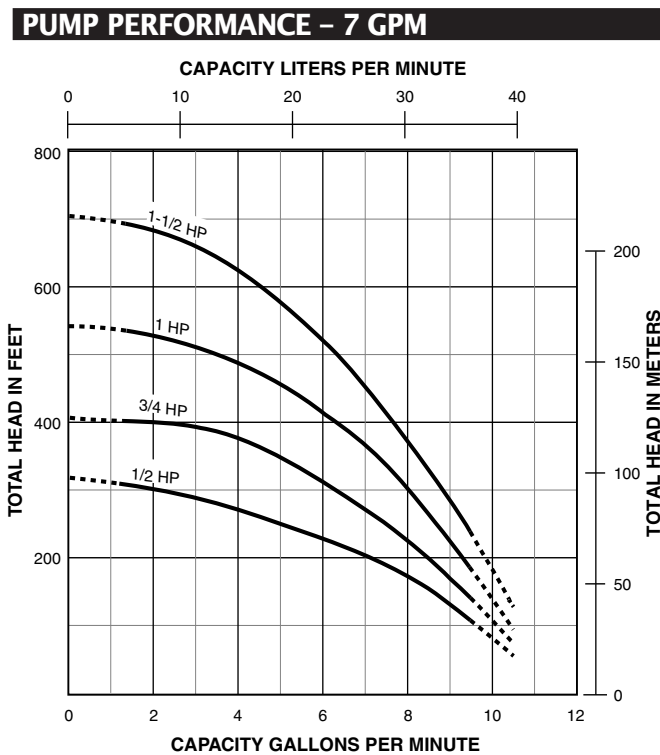
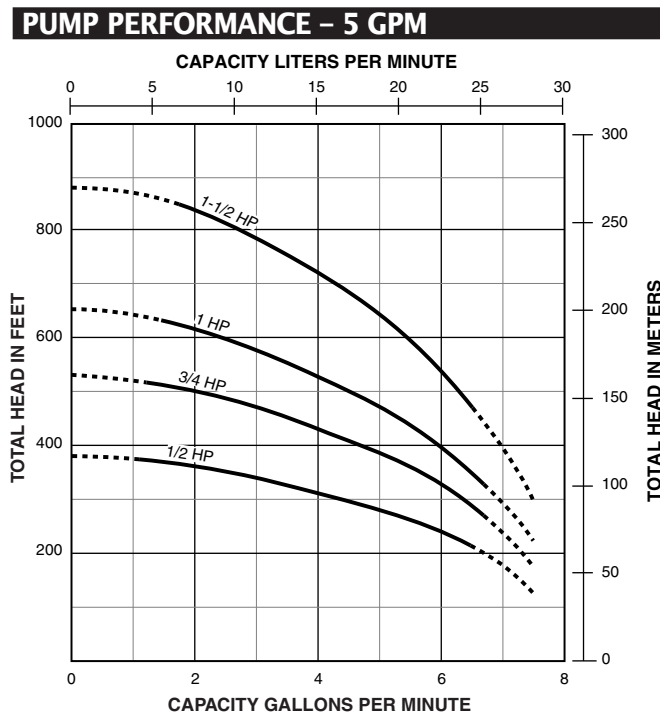

Tested and rated in accordance with Water Systems Council standards.

NOTE: Pumps installed with a PRO-Source™ tank require a 100 PSI relief valve. Pumps installed with a conventional tank require a 75 PSI relief valve. Relief valve must be capable of relieving entire flow of pump at relief pressure.